

SIG.CONV – signal converter

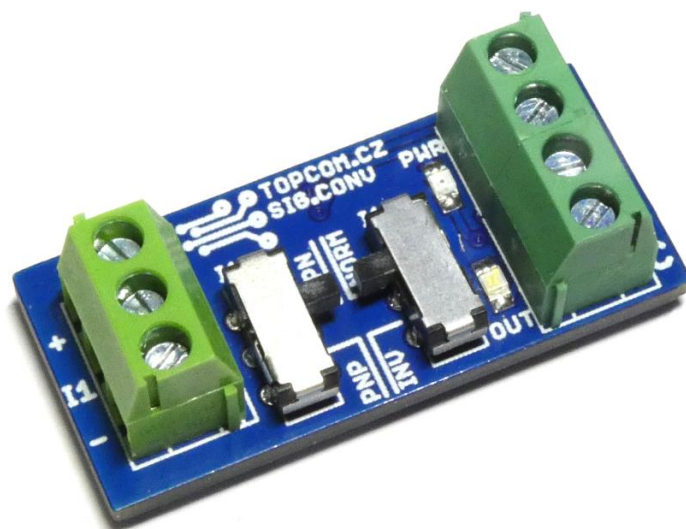

Buy this item at:



<https://www.topcom.cz/sigmer2/>

--- or ---



<https://www.ebay.com/str/cncprobes>



Important: this device needs connection and installation. Seller does not take any responsibility for any damage or injury caused by using of this device. Read carefully documentation for your CNC machine and motion board.

Description:

SIG.CONV is a device, allows converting different signal types (NPN/PNP, NO/NC) to the output signal. Output signal is galvanically isolated from the input and power circuit. Because of isolation it can be used also as a signal coupler.

Main features:

POWER	
Power voltage (Vcc)	5-24V DC
Power consumption	<25mA
INPUTS	
Input current	1.6mA @ Vcc=5V
	4.5mA @ Vcc=12V
	9.5mA @ Vcc=24V
Input polarity	NPN/PNP
OUTPUT	
Output type	Dry contact
Output voltage	24V max.
Output current	20mA max.
Output phase	NORMal/INVerted
Transitional ON time	<20us
Transitional OFF time	<500us
DIMENSION	
Width x Height	36x16mm

Description:

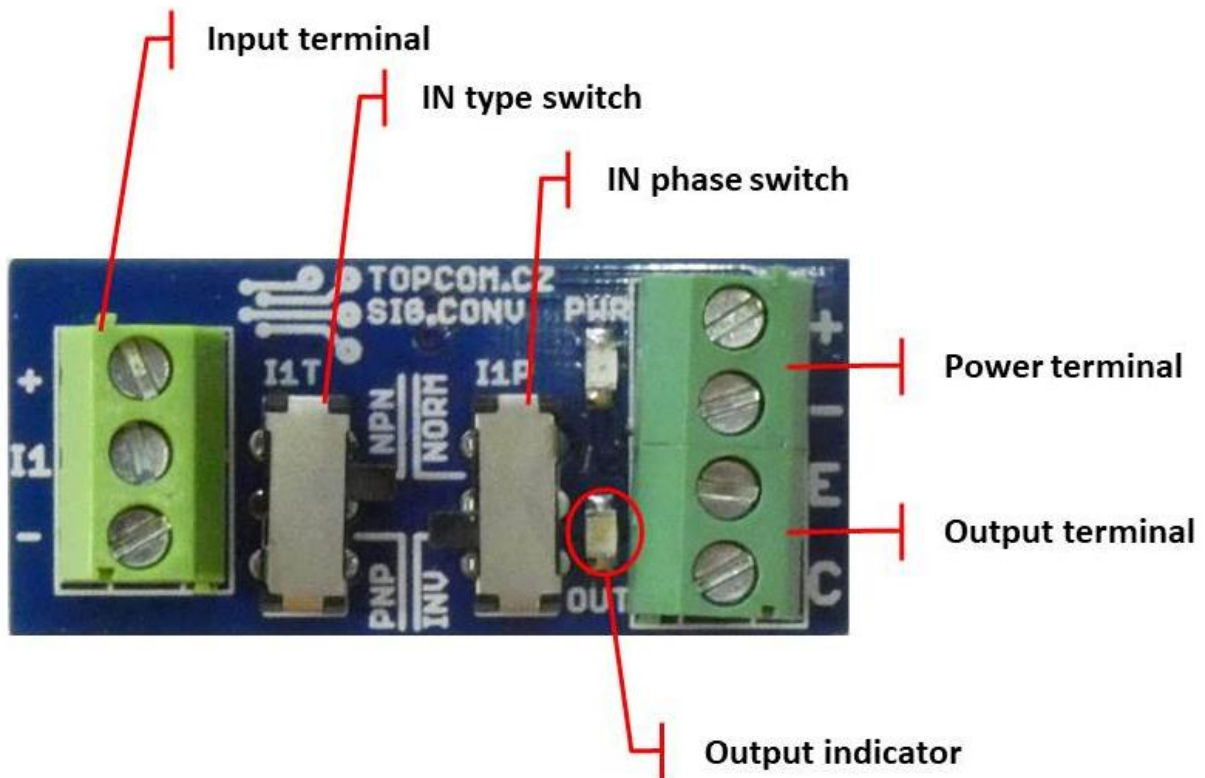

- **Input terminal:**
 - + ... sensor power
 - In ... input clamp
 - ... sensor GND
- **Input type switch:**
 - NPN** ... input is configured for NPN output from a sensor (switching to -)
 - PNP** ... input is configured for PNP output from a sensor (switching to +)
- **Input phase:**
 - NORM** ... output is active, if input is activated (for NO sensors)
 - INV** ... output is active, if input is inactive (for NC sensors)
- **Output indicator:**

LED is lighting, when output is active.

- Output terminal:

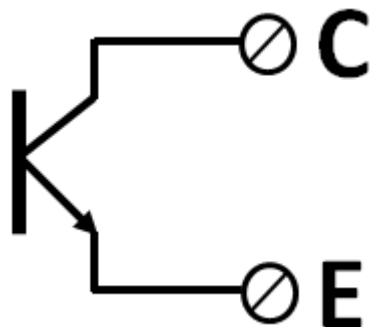

Input wiring for NPN sensor:



Input wiring for PNP sensor:



Input wiring for simple switch:





Sensor is powered from the main power input (+ and -).

If the sensor must be powered from different power source, solder switches on the bottom side must be open! Input channel is isolated from the rest of the board.

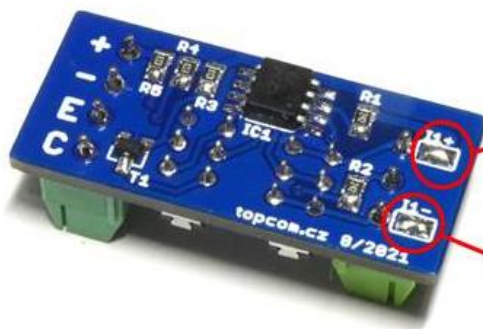

Solder switch connects positive terminal to input power

Solder switch connects negative terminal to GND

Output wiring:

Wiring to motion control board with PNP inputs (activated by positive voltage)

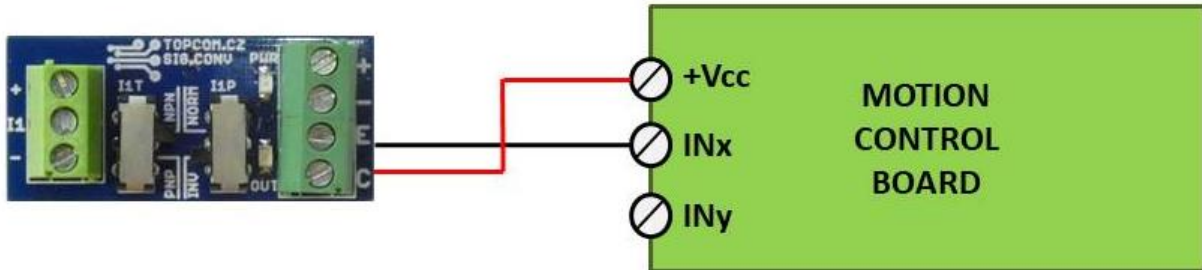

Wiring to motion control board with NPN inputs (activated by grounding)

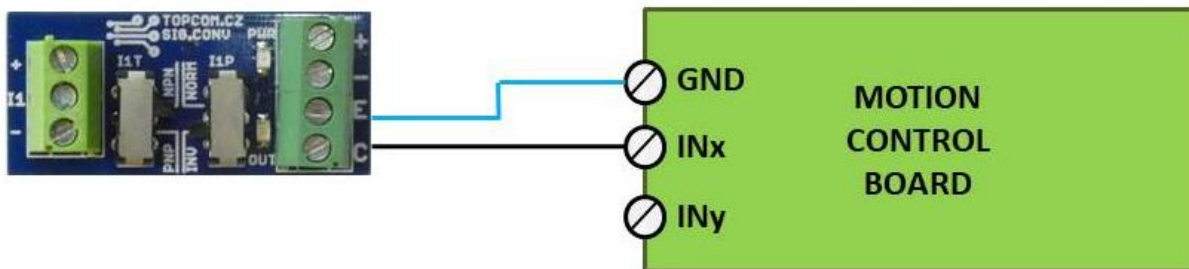

Output terminal is potential – free, isolated from the power supply and input channels also.



Do NOT exceed the maximum output current and voltage.

Board setup procedure:

1. Connect the power source.
2. Connect the sensor or switch to the input.
3. Connect the output to the motion control board.
4. Set the correct input type for the input (NPN/PNP) by I1T switch:
 - If the input type is set correctly, output indicator reacts to the sensor triggering.
5. Set the correct signal phase by I1P switch.

